

The Cartesian Coordinate System and Euclidean Geometry – A Happy Coincidence?

Robert Atkinson June 2013

Abstract:

The Cartesian Coordinate System (CCS), although increasingly adopted as the working environment of architectural design, does not have a simple relationship with the physical world. This paper examines the role of Euclidean geometry as a mediating entity. It explores the relationship between Euclidean geometry and the world and its validity as a model of three-dimensional space. It then traces the development of the CCS from its origins in René Descartes' algebraic analysis of the geometrical methods of Greek antiquity, before finally examining the mathematical connection between the CCS and Euclidean geometry.

Introduction:

Since the advent of CAD (Computer Aided Design) in the 1980s, architectural design has increasingly adopted the Cartesian Coordinate System (CCS hereafter) as its working environment. The CCS is the system of three mutually perpendicular coordinate axes, usually given the letters X, Y and Z, which define the three dimensions of the working environment and allow objects to be positioned accurately. Every operation in CAD, whether it involves snapping to a point on the screen or engaging directly with the program through scripting techniques, involves a representation within the program and on the screen in terms of X, Y and Z coordinates. This representation corresponds to the architect's design intentions within three-dimensional physical space, and on a practical level the connection between the CCS and real space seems immediate, almost as if the world itself were overlaid with an equivalent coordinate grid.

In reality, of course, there is no grid, and the link between the three dimensions of the CCS and the real three-dimensionality of the world is not so simple. There has to be a mediating entity which is capable of a meaningful connection with the abstract, numerical CAD environment on one hand, and the physical, substantial spatial environment on the other. That entity is Euclidean geometry – not just in its usually understood sense as a science of space, but also in a more particular sense as the often unacknowledged but essential companion to the CCS. In this paper I will examine this Euclidean 'glue' – its philosophical connection with the world and its mathematical connection with the CCS, taking in along the way René Descartes' algebraic analysis of the geometry of Euclid and Greek antiquity ('Cartesian' is derived from the Latinized version of his name), and the development of his analytical method into a general working environment suitable for architectural design.

1. Euclid

One way of understanding geometry is as a kind of visual mathematics. Its components – points, lines, circles, etc – are different from those of arithmetic and algebra, but like all branches of mathematics geometry can be described as the manipulation of symbols according to rules.¹ In this view geometry is ideal: it does not depend on experience for its veracity, and relationships between geometrical entities can be developed purely on the basis of its logical and formal structure without reference to the 'real' world. But we might also think of geometry as a system for measuring dimensional qualities of physical, worldly things – this is, after all, where the word originates. In this view geometry is essentially the science of space; not ideal but empirical, based on our experience of the three-dimensional relationship between objects.

A significant feature of Euclidean geometry is that it suggests an engagement between these two profoundly different modes of thought and experience. Euclidean geometry is the comprehensive system of definitions, postulates and propositions described in Euclid's 'Elements' of ca. 300 BC, which until the middle of the 19th Century was accepted almost without question as an accurate description of space. It is often described as based on the physical construction of geometrical objects, and sometimes (though less accurately) on 'ruler and compass' methods.² However in spite of these empirical connotations it lies almost entirely in the first, ideal category. Its logical structure is a self-contained system without any necessary connection to physical entities at all.³ The responsibility for its 'embodiment' lies with just three of the five postulates at the beginning of the work, which combine with the definitions which they immediately succeed to give a dual description of the most primary geometrical objects – point, line and circle. The division between the two views of geometry is expressed here in elemental form. The definitions are ideal, specifying in abstract terms basic relationships between the primary objects. The postulates are empirical, based on construction and motion.

Some definitions:⁴

1. A point is that which has no part.
2. A line is breadthless length.
3. The extremities of a line are points.
4. A straight line is a line which lies evenly with the points on itself.

15. A circle is a plane figure contained by one line such that all the straight lines falling upon it from one point among those lying within the figure are equal to one another.

The first three postulates:

1. To draw a straight line from any point to any point.
2. To produce (extend) a finite straight line continuously in a straight line.
3. To describe a circle with any centre and distance (radius).

Euclid does not explain how the definitions and postulates might combine to create the essential link that we are looking for, but he puts them in a proximity which suggests a close relationship. This has provided the opportunity for much discussion on how ideal and empirical geometry can in fact be brought together, and how, as a result, the Euclidean system can act as an analytical and predictive tool in the science of space. I will condense the possible responses to this into three broad categories:

The first could be called 'common acceptance'. When statements are distilled to such a level that they are no longer demonstrable in terms of other statements, their truth has to rely on a commonly held understanding. Heath, in the introduction to his translation of Euclid,⁵ quotes Aristotle at length on this point. In his discussion of the nature of hypotheses, Aristotle (writing a few decades before Euclid) makes the distinction between definitions and postulates: "Definitions only require to be understood" and this understanding can be generally assumed. The acceptance of postulates, however, is not assumed: "[W]hen the learner either has no opinion on the subject or is of contrary opinion, it is a postulate." The ideal token that the definition represents may be understood, but it needs some persuasion (and possibly suspension of disbelief) to connect it to the 'real' postulate. We need to accept, for example, that it is actually possible to 'draw a "breadthless length" from any point to any point', despite the obvious objection that any real drawing involves making a mark with both length and breadth. But once we do accept that a line can be, simultaneously, something drawn and a breadthless length, we are ready to apply Euclidean theory to the physical world.

The second is 'intuition', drawing on Immanuel Kant's theory that space is not physically real but part of the perceptual apparatus we need to make sense data meaningful. Definition and postulate can be bound up together in (in Kant's terminology) concept and intuition: the postulate does not add something separate to the definition, but it expands it and becomes part of it. In his study of Leibniz and Kant on Euclid, Jeremy Heis quotes the following passage from Kant's student Johann Kiesewetter:

“So it is, for example, a postulate to draw a straight line between two points. The possibility of the straight line is given through its concept, [and] it is now postulated that one could exhibit it in intuition. One can see right away that through the drawing of the straight line its concept is not augmented in the least, but rather the issue is merely to ascribe to the concept an object of intuition.”⁶

As Heis explains, the postulate “secures that the definition is real ... and not merely nominal”. Kant’s very influential theory of space, in which the complete validity of Euclidean geometry is implied, became discredited with the discovery that spaces are conceivable which are not Euclidean. However the strong combination of definition and postulate which the theory allows is perhaps closest to our own ‘intuition’ of space.

I will call the third category ‘conditional’, following the adoption of non-Euclidean geometries by Albert Einstein in his theories of relativity. Einstein, no sympathiser with Kant but sharing the concern over the relationship between the real and the nominal, wrote:

“To be able to make such assertions (about the behaviour of real objects) geometry must be stripped of its merely logical-formal character by assigning to the empty conceptual schemata of axiomatic geometry objects of reality that are capable of being experienced. To accomplish this, we need only add the proposition: Solid bodies are related, with respect to their possible relative positions, as are bodies in Euclidean geometry of three dimensions.”⁷

The ‘empty conceptual schemata’ refer to the definitions. The postulates are condensed into one proposition: “Solid bodies are related ...” However the argument in this quotation is a prelude to a discussion about the validity of Euclidean geometry in relativity theory. The proposition is not a postulate but a hypothesis, and the engagement of the real and ideal is conditional upon its testable truth.

An absolute connection between ideal Euclidean geometry and the physical world may therefore be impossible to find. ‘Common acceptance’ and Kantian ‘intuition’ give us a hint of solid ground, but Einstein’s need for qualification must be examined before we can see where we can actually claim Euclidean geometry to be valid.

Doubts about Euclidean geometry arise from the definition of parallel lines and the corresponding ‘parallel postulate’:

Definition 23: Parallel straight lines are straight lines which, being in the same plane and being produced indefinitely in either direction, do not meet one another in either direction.

Postulate 5: That, if a straight line falling on two straight lines make the interior angles on the same side less than two right angles, the two straight lines, if produced indefinitely, meet on that side on which are the angles less than the two right angles.

Since Euclid's time it has been recognized that while the parallel postulate is necessary for the logical structure of the Euclidean system it is not as simple or self-evident as the others.⁸ Many unsuccessful attempts were made to prove it, until in the mid-19th Century research demonstrated firstly that it was possible to construct an equally valid logical system without the parallel postulate, and secondly that this system could be extended to define theoretical spaces in an infinite number of dimensions.⁹ This was the model of space that Einstein needed for his General Theory of Relativity of 1915 in which gravity is explained in terms of 'curvature' in four-dimensional spacetime, a theory which has since proved to correspond with observation at an astronomical scale.¹⁰ Within this generalized 'non-Euclidean geometry', three-dimensional Euclidean geometry with its parallel postulate is a special case, potentially valid but not necessarily so.

While we can't say unconditionally that Euclidean geometry represents the universe in all its characteristics, we can make a qualified assertion that it represents the world at a human scale and in three dimensions. The gap between real and ideal remains, but if within our own experience we can say, with Einstein, that "solid bodies are related, with respect to their possible relative positions, as are bodies in Euclidean geometry of three dimensions" then we have in Euclidean geometry a working model of the world which can indeed be analytical and predictive in the way that we need it to be. What remains, therefore, is to examine the CCS itself and how it can engage with Euclidean geometry.

2. Descartes

An illustration of a geometrical figure exists in a kind of space. Understanding the figure involves 'seeing it' in the spatial context implied by its geometry. However, this perceived context is local to the figure; two neighbouring figures may have different implied geometrical spaces, and understanding them both may involve some perceptual switching. The CCS brings unity and definition to the spatial environment of geometrical figures: it precedes them and defines the spatial characteristics of the figures themselves and their surroundings. This definition was not fully achieved by Descartes – that was not the aim of his investigation – but he set in motion a sequence of developments which, nearly two centuries later, emerged as the general spatial framework which bears his name.¹¹

Descartes' work can be divided broadly into three categories: metaphysical philosophy (represented by the 'Meditations on First Philosophy', 1641), physics (distributed between essays appended to the 'Discourse on the Method', 1637, and 'Principles of Philosophy', 1644), and mathematics ('La Géométrie', also appended to the 'Discourse' – I will refer to it in its French form to avoid confusion with the general term). In many histories of the philosophy of space it is his work on physics, and on the nature of space in particular, which naturally forms the focus of attention.¹² He does not come out well in this story: his reluctance to accept the existence of a vacuum and his insistence that the only possible cause of interaction between solid objects is via collision between particles gave Newton the opportunity for some caustic criticism,¹³ and his ideas are generally presented as a false turn in the development of spatial theory.

La Géométrie, however, is a pivotal work in the development of what has become known as analytic geometry – the application of algebraic techniques to the analysis of geometric curves.¹⁴ Descartes developed in La Géométrie the idea of reference lines which are not part of the curve under analysis, but are used to obtain a numerical value for each point on the curve. The method for obtaining the numerical value can then be expressed as an algebraic equation. It is these reference lines which developed into the CCS.

Near the beginning of Book II of La Géométrie there is a figure which illustrates Descartes' analytical method particularly well. He illustrates it with the diagram in figure 1.¹⁵

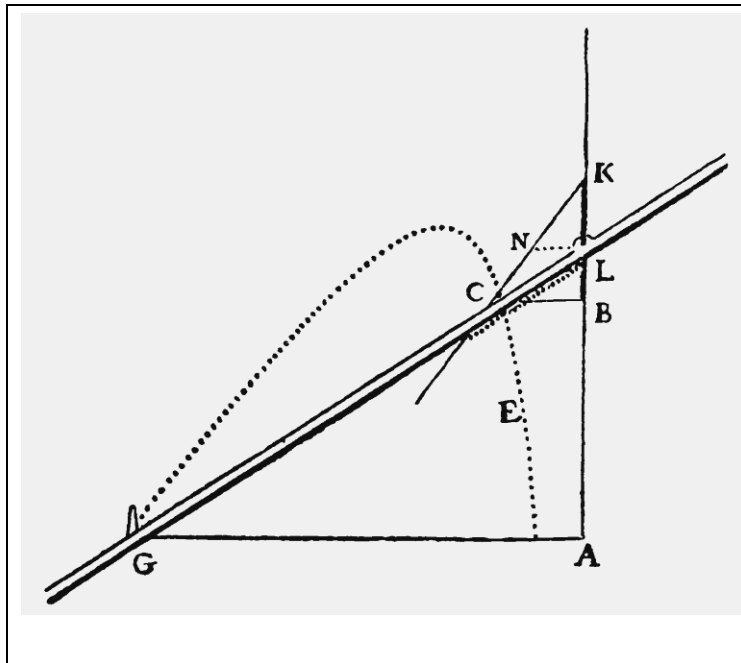

1

René Descartes, 'La Géométrie', 1637 (p. 50). Diagram showing an arrangement for drawing a hyperbola.

In his study of geometric analysis by Descartes and the ancient Greeks, A. G. Molland suggests two types of curve 'specification': by 'genesis' (examining how a curve is constructed), or by 'property' (finding a quantitative property obeyed by all points on the curve)¹⁶. If we look at Descartes' figure with these types of specification in mind it is the genesis of the curve which is evident at first glance, through the apparent interaction of several components:

1. A ruler GL which can swivel against a fixed pin G.
2. A triangular figure KNL which can move vertically and is connected to the ruler at L. The side KN is extended by a variable distance to meet the ruler at C. This conjunction generates the curve as ruler and triangle move.
3. A vertical line AK against which the triangle KNL slides. The horizontal lines GA and CB do not have a role in this 'physical' construction, but are necessary for the specification of property described below.

Descartes takes as his task the derivation of the property specification of the curve by an examination of the geometrical relationships of the components of genesis. In his analysis he describes the arrangement as shown in figure 2, using lowercase letters to describe the lengths of lines between the points indicated by capitals: a , b and c for known lengths which remain constant as the ruler and triangle move; x and y for unknown lengths which vary with movement. He proceeds to construct a series of algebraic equations from the relationships between these lengths, based on the proportional properties of two pairs of similar triangles: GAL/CBL and KCB/KNL. These

relationships are constant whatever the position of the ruler GL (as long as θ lies between 0 and ϕ), and after some calculation are expressed by Descartes in a single equation:

$$y^2 = cy - \frac{cx}{b}y + ay - ac$$

Descartes uses this unusual version of an equation (with 'y' present on both sides) because his intention is to demonstrate its 'degree' – the fact that it contains a square of y. It is, in fact, an equation for a hyperbola.¹⁷ The trace produced by this expression is naturally identical to the geometric construction it is based on.

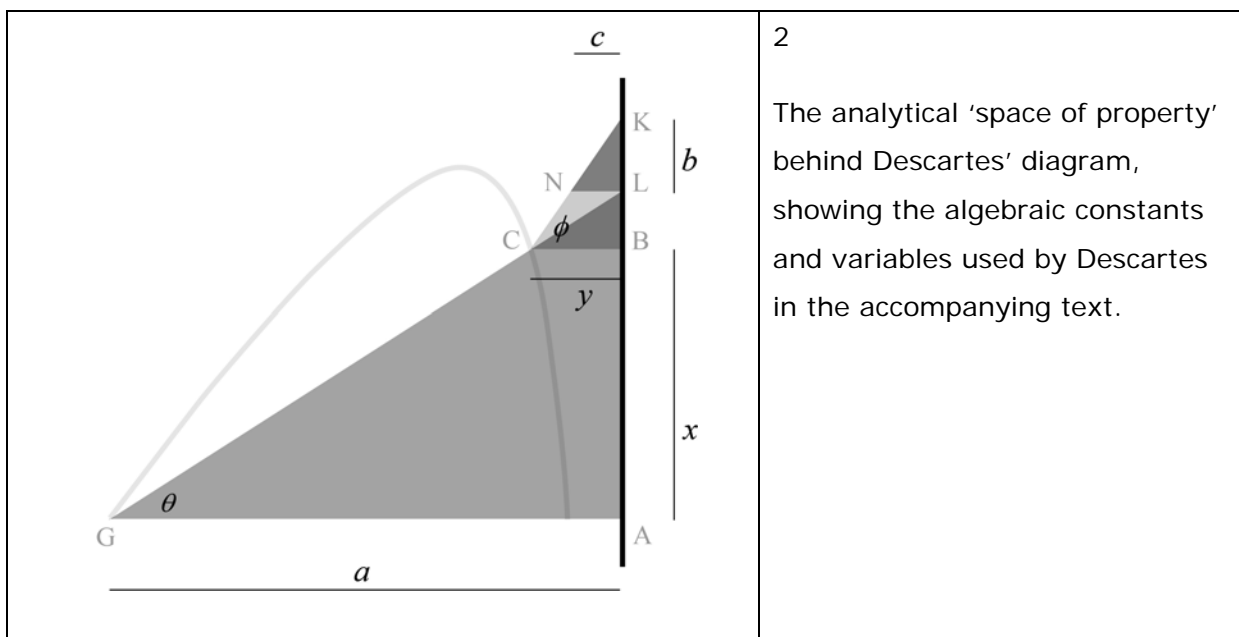

The curve and its constructive genesis represent for Descartes the methods of Greek antiquity, and it might seem that by demonstrating a relationship between physical construction and its algebraic representation Descartes had achieved 'in one bound' the synthesis between real and ideal that we sought in the last section. This, however, would be to misunderstand his intention. Like every other mathematician of his time Descartes accepted the validity of Euclidean geometry as a description of space. In bringing together genesis and property he was not setting ideal geometry against physical geometry in order to demonstrate a proof of the Euclidean system. His concern was to bring exactness to the geometry of Greek antiquity, and he saw algebra as the way to achieve this.¹⁸

The dual specification of genesis and property suggests two types of spatial understanding of Descartes' figure. The literally-drawn mechanical components of genesis imply a space necessary to accommodate their movement, limited to what one

perceives as the range of contact between them. The more hidden diagram of property in figure 2 implies a different kind of space, where every point in the area to the left of the line AK and above the line GA can be specified in relation to them, whether or not it lies on the curve. AK and GA (which do not have to be perpendicular for Descartes' calculations, although CB must be parallel to GA) define, in numerical terms, a space of possible values of x and y . It is this less explicit but more general 'space of property' which has the potential to unite the spatial characteristics of the figure with its surroundings. In the next section I will sketch out the way in which the space of property developed from a 'by-product' of Descartes' analysis of the genesis of curves into a fully-fledged representation of three-dimensional space.

3. The Development of a Three-Dimensional Coordinate System

The development of analytical geometry as a geometric/algebraic discipline is thoroughly documented.¹⁹ Its development as a three-dimensional 'working environment' is less well-known. In this section I will sketch this development using three examples chosen for the way in which they illustrate this particular aspect.

At the end of Book II of *La Géométrie* Descartes includes a brief and tantalizing description of the possibility of three-dimensional curves, without specific examples or illustrations. Almost a century later Claude Rabuel picked up where Descartes had stopped. His 'Commentaires sur la Géométrie de M. Descartes' of 1730 is an expanded and annotated version of Descartes' work with many additional illustrated examples, including an interpretation of Descartes' three-dimensional hint.²⁰

Descartes had said:

"... my remarks can easily be made to apply to all those curves which can be conceived of as generated by the regular movement of the points of a body in three-dimensional space. This can be done by dropping perpendiculars from each point of the curve under consideration upon two planes intersecting at right angles ..." ²¹

Rabuel illustrates Descartes' idea with (among others) figure 3:

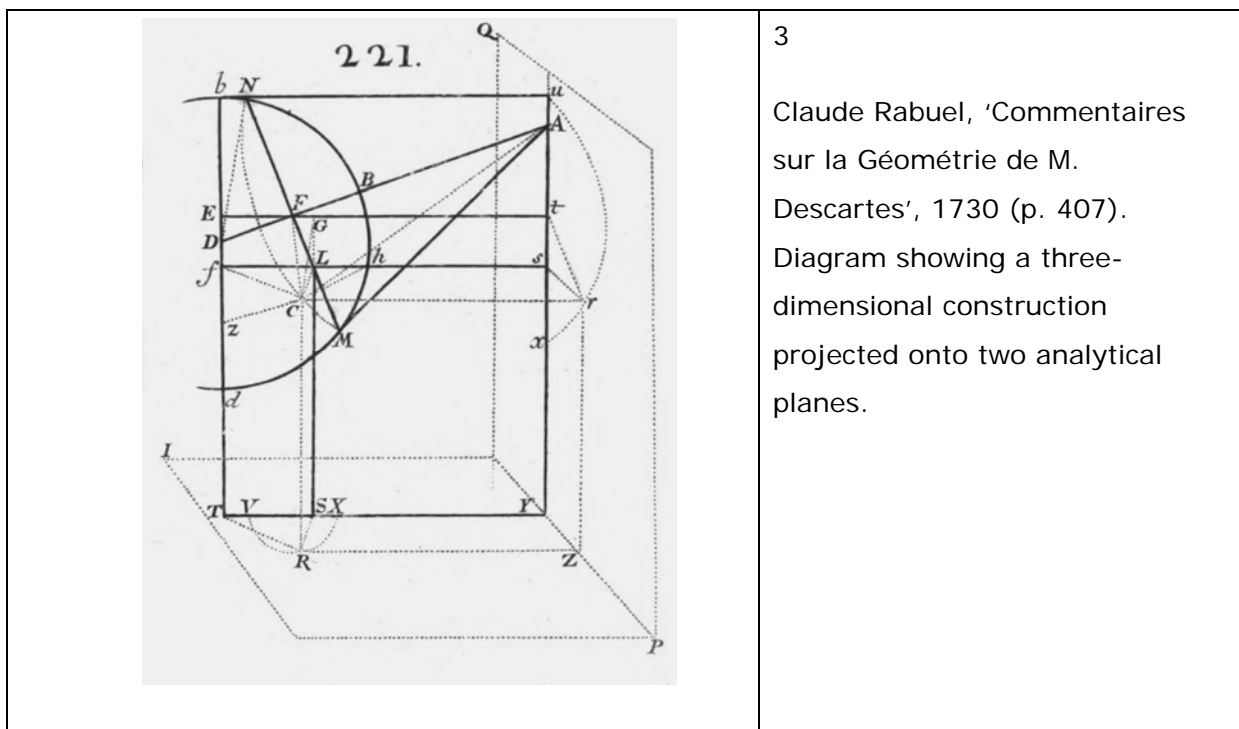

The illustration is of a sphere (indicated by the partial circle) and a moving rod AM hinged at A, whose range of contact with the sphere is shown by the dotted curve NCM. Rabuel's method (following Descartes' suggestion) is to project the curve onto two perpendicular planes IP and QP, and to derive equations using a technique similar to Descartes'. The division between specification by genesis and property is greatly aided by the apparent space of the figure: the components of genesis are concentrated in its centre while analysis of property takes place mainly on the projection planes.

Both Descartes and Rabuel were evidently thinking about the portrayal of space, and one might think that a complete three-dimensional spatial reference system is present in this figure. However the planes themselves are not the entities which define it.

Relationships between components of the figure are established against lines bound up with the figure itself, and the planes are purely 'projection screens' for property analysis. Only two equations are necessary for the algebraic definition of a curve in three dimensions,²² so only two planes are required, in what is essentially a two-dimensional analysis of three-dimensional objects rather than the establishment of a fully three-dimensional space.

A more definite indication of a three-dimensional framework was given by Alexis Clairaut in his contemporary work 'Recherches sur les Courbes à Double Courbure'.²³ Written in 1731, the 'Recherches' is a comprehensive account of curved lines in three dimensions ('curves of double curvature') and curved surfaces. The components of genesis, still very apparent in Rabuel's diagram, are absent from Clairaut's work. His main aim is to extend the analysis of property through calculus to find lengths of curves, areas of surfaces and volumes of solids.

The first four diagrams (figure 4) show the development of an analytical framework for a curve ANN. The reference lines (P, Q and R) define three planes against which the curve is projected. Clairaut never mentions the word 'space' except as the area of a surface, but this framework represents a much clearer definition of a containing space than the two planes of Descartes and Rabuel: although the spatial framework is attached to the curve, and in a sense remains part of it, it is nevertheless complete as a framework and represents three dimensions around the curve.

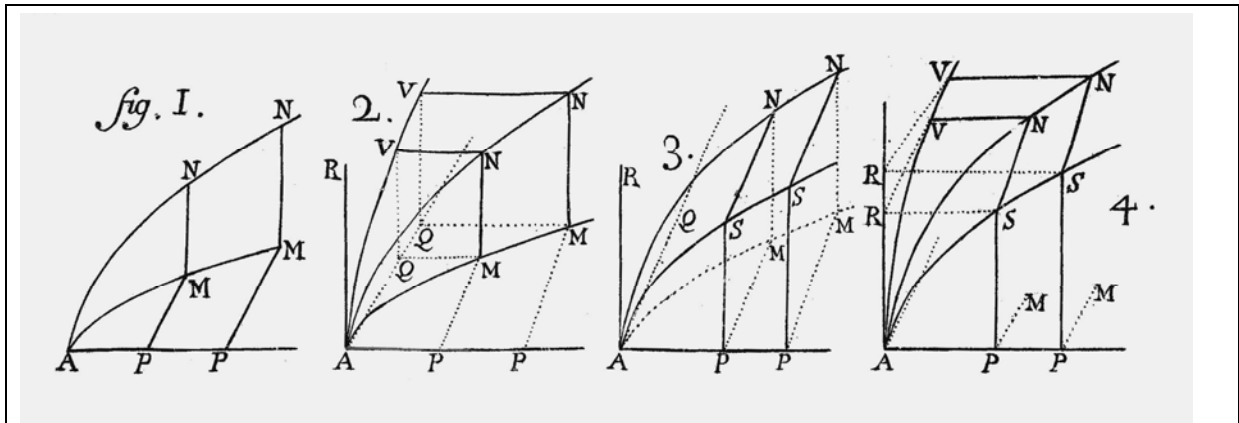

4

Alexis Clairaut, 'Recherches sur les Courbes à Double Courbure', 1731. First four diagrams, showing the development of an analytical framework for a curve ANN.

Clairaut's study, like those of Descartes and Rabuel, is an encyclopaedia of solutions to quite complex geometrical problems rather than an explanation of the coordinate system itself. However, there is one instance where, perhaps not realising its full significance, he expresses a theorem of primary importance to the CCS. In his investigation of the length of a curved line (figure 5) he examines the formula for a small increase, illustrated in the figure as the length Nn of the curve ANn. Using differentiation, he concludes that " $\sqrt{dx^2 + dy^2 + dz^2}$ is therefore the general formula for the length of curves of double curvature",²⁴ a statement very close to the 'signature' of the Cartesian/Euclidean relationship, which I will explain in the next section.

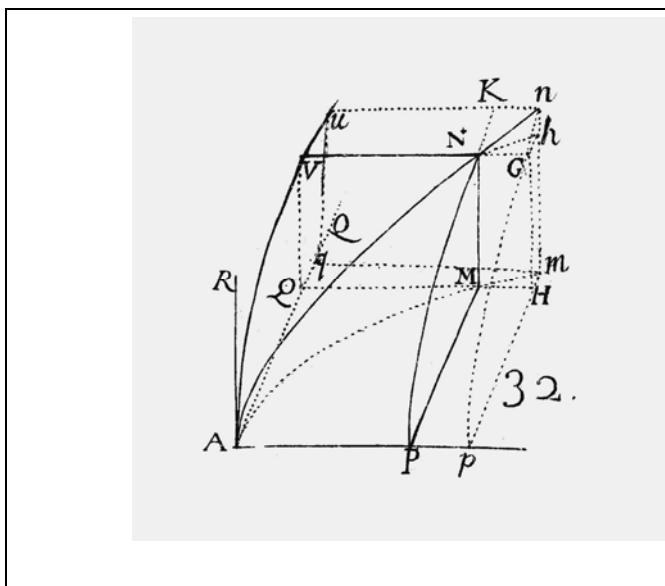

5

Alexis Clairaut, 'Recherches sur les Courbes à Double Courbure', 1731. Diagram illustrating the incremental development of a curve ANN.

The recognition in a more general sense of elemental objects in analytic geometry took rather longer, and my next example comes some 70 years after Clairaut. Jean-Baptiste Biot's 'Essai de Géométrie Analytique' ²⁵ of 1802 was enormously influential, particularly in America where, in translation, it was a main textbook in schools of military engineering. Biot takes a different approach from the previous examples and starts from first principles:

"As all geometrical investigations refer to the positions of points, our first step must be to show how these positions are expressed and fixed by means of analysis... Space is indefinite extension, in which we conceive all bodies to be situated." ²⁶

It is significant that Biot not only begins the discussion with single points, but that his analysis extends to the 'space' that contains them. The simple illustrations below contain all the essential components of the modern CCS: a stated recognition that it is a model of space, three perpendicular axes marked X, Y and Z and three corresponding planes XY, YZ and XZ. All three planes have equal status as the entities which define the space. Figures 6 and 7 illustrate the definition of two elemental objects – a point and a line – within this space. Figure 6 shows a single point M with its projection onto all three planes at M', M'' and M'''. Figure 7 shows a line MM' with part of the construction of its projection. The projection method relates the objects to the coordinate system in a manner similar to the examples of Descartes, Rabuel and Clairaut discussed above, but what marks Biot's work out as different is the establishment of a coordinate space before the definition of elemental objects in relation to it, and the separation of the objects from the space.

<p>6</p> <p>Jean-Baptiste Biot, 'Essai de Géométrie Analytique' 1802. Diagram showing the position of a single point M in a coordinate system. (redrawn by Francis Smith – see note 26).</p>	<p>7</p> <p>Ditto, showing a line MM'.</p>

With Biot, the CCS arrived at a stage of development where the coordinate system is no longer just the space of analysis of given shapes, but a space where shapes may be generated and defined mathematically through the arrangement of elemental objects. The practical development of methods for shape generation was still to come, but Biot and his contemporaries had set the stage.

4. The Mathematical Connection

I have examined, separately, the relationship between Euclidean geometry and the world, and the development of the three-dimensional CCS. To find a relationship between the CCS and the world we need to find a connection between it and Euclidean geometry. This is essentially a mathematical connection – the connection between two ways of expressing geometrical relationships. If it can be demonstrated that the algebraic relationships inherent in the CCS correspond to the descriptive relationships of Euclidean geometry, the worldly aspects of Euclidean geometry can be attached to the CCS.

Compare the algebraic equation $a/b = c/d$ with Euclid's Proposition 2 in Book VI:

"If a straight line be drawn parallel to one of the sides of a triangle, it will cut the sides proportionally... For let DE be drawn parallel to BC, one of the sides of the triangle ABC: I say that, as BD is to DA, so is CE to EA." (figure 8) ²⁷

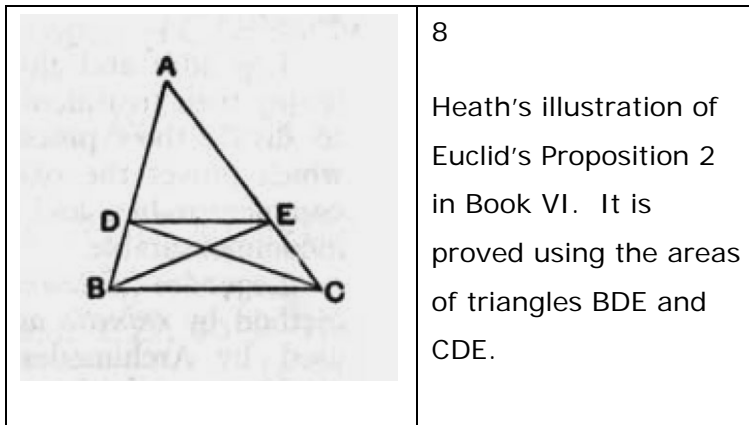

Despite their differences there is a clear relationship between these statements: although the algebraic equation is abstract and unattached, there is an equivalent expression of proportionality in each. If we combine the expressions by substituting a for BD, b for DA, c for CE and d for EA, we can see that the statement $a/b = c/d$ becomes true and attached within the figure (figure 9).

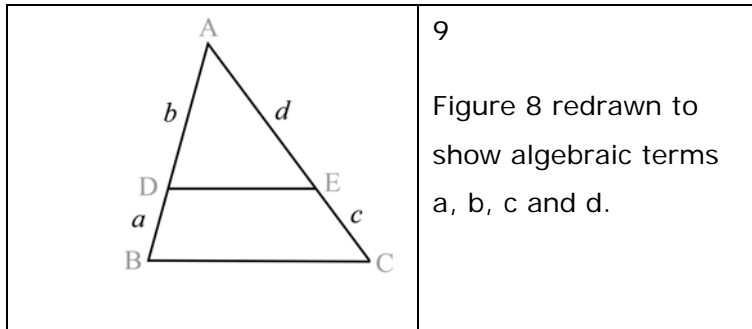

It is then possible to use the rules of algebra to show that $(a+b)/b = (c+d)/d$, extending Euclid’s analysis of the ratio of the segments of either side to demonstrate that the ratio of the overall sides of the larger triangle to the smaller is also equal, which is apparent but not explicit in the proposition. It is also possible to say (for instance) that $a = bc/d$, which is more than a simple expression of proportion, and is not immediately apparent. It is these principles, developed from proportionality, which Descartes used in his algebraic analysis (figures 1 and 2).

Now consider the expression $s^2 = x^2 + y^2$ and Euclid’s Proposition 47 in Book I:

“In right-angled triangles the square on the side subtending the right angle is equal to the squares on the sides containing the right angle.”
 (figure 10) ²⁸

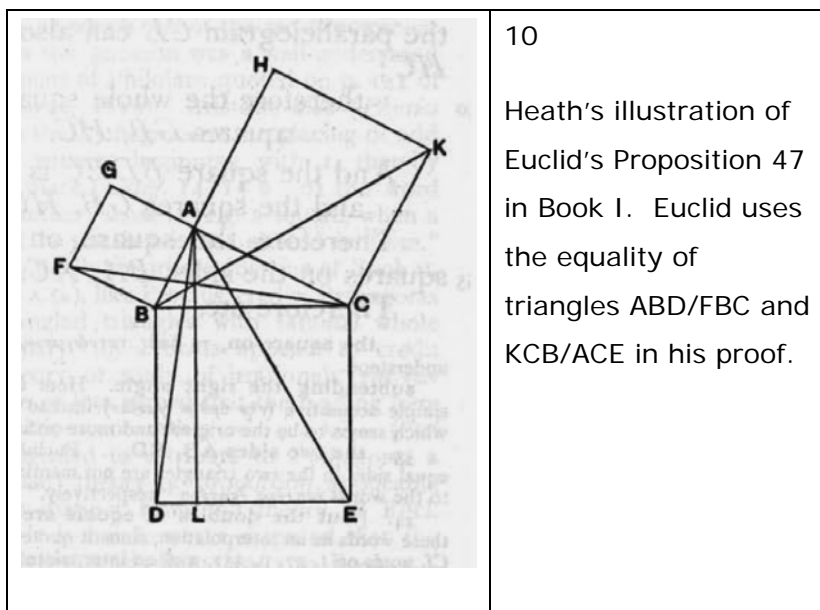

This is the Pythagorean theorem, which Euclid proves using squares attached to the triangle. As in the example above, the algebraic equation by itself is an abstract and unattached statement until we combine it with the geometrical figure as shown in figure 11. The equation then takes on an embodied meaning as an alternative way of expressing the relationship between Euclid's 'side subtending the right angle' (hypotenuse) and 'sides containing the right angle'. It is 'grounded' by the Euclidean proposition in the physical world: algebraic squares are equivalent to 'real' squares in space.

We can consider this triangle to represent a 'space' defined by a horizontal x axis and vertical y axis; their meeting point is the 'origin'. The equation $s^2 = x^2 + y^2$ means that any line drawn between the x and y axes has the same relationship with the sides of the triangle formed; in other words the length s can always be derived from the lengths x and y . This simple but important fact is a defining property of the space.

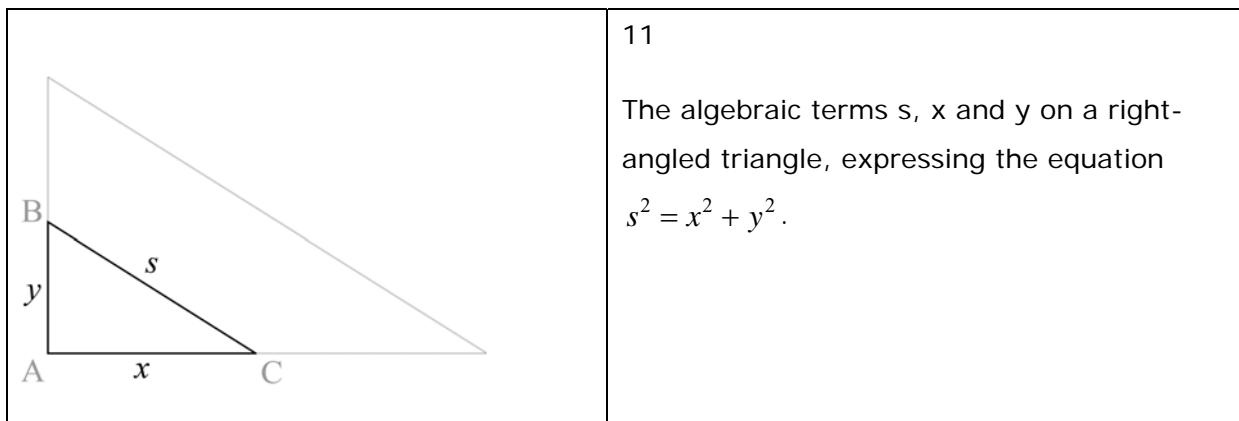

Euclid was uncomfortable with the idea of moving a figure in relation to another. While it may seem intuitive that one can do this, it does not follow from any of the postulates that the defining properties of a figure are retained with movement, and Euclid only allowed it a few times in his work.²⁹ Algebra, however, allows us to perform this necessary function ('translation' in modern terminology) by substituting an expression for a variable, so rather than writing $s^2 = x^2 + y^2$, we can write $s^2 = (x_2 - x_1)^2 + (y_2 - y_1)^2$. This permits another right-angled triangle to be drawn at a position x_1, y_1 (figure 12). This triangle can be thought of as breaking free from the origin, as an 'object' within the 'space', but it has been constructed using the same principles as the 'space' and will share its properties wherever it is placed. This is the connection between elemental object and coordinate space demonstrated by Biot in three dimensions (figures 6 and 7).

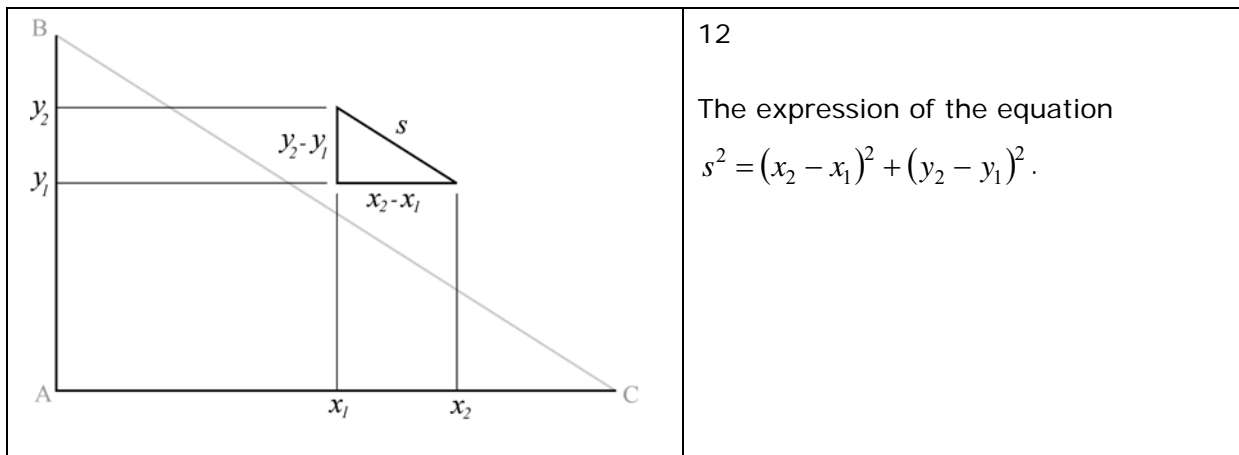

Expansion to three dimensions is straightforward. If a z axis is added perpendicular to x and y , the length formula for a line in the three dimensions that result is

$$s^2 = x^2 + y^2 + z^2 \text{ in general terms, or } s^2 = (x_2 - x_1)^2 + (y_2 - y_1)^2 + (z_2 - z_1)^2 \text{ for a specific line.}$$

Extension to shapes other than straight lines is given by a differential function of these formulae. Taking any curve, we consider what happens as we increase its length by an infinitesimal amount. As the increased length tends towards zero its formula tends towards that of a straight line. This is written using the differential symbol 'd', as $ds^2 = dx^2 + dy^2 + dz^2$. This is the standard 'distance formula' for Cartesian space, and applies to any infinitely close points within it; in other words, to any infinitely small part of any curve – the idea that was expressed by Clairaut as “the general formula for the length of curves of double curvature” (figure 5).

The distance formula $ds^2 = dx^2 + dy^2 + dz^2$, with illustrative backup from the theories of proportion and translation discussed above, is in fact all that is needed to confirm that the CCS is a valid model of Euclidean geometry.³⁰ We can go further than this, however. While adhering to Euclidean principles, the CCS frees itself from the restrictions of construction that characterises Euclidean geometry and achieves a potentially infinite, homogeneous spatial model: it has a simple geometrical structure which is the same everywhere and is shared with objects placed anywhere within it. Einstein put it like this:

“[In Euclidean geometry] all spatial relations are reduced to those of contact... Space as a continuum does not figure in the conceptual system at all. This concept was first introduced by Descartes, when he described the point-in-space by its coordinates. Here for the first time geometrical figures appear, as it were, as parts of infinite space, which is conceived as a three-dimensional continuum.”³¹

Conclusion: Two Geometries or One?

I have based this paper on the necessity of Euclidean geometry as an intermediary between the CCS and the world. But if the mathematical connection I have made between the CCS and Euclidean geometry is as strong as I have claimed, it must inherit all of the Euclidean system's rigour. If it does, it must be legitimate as a geometry in itself. We must then ask the question: Why do we need two geometries? Why all this complication? If the CCS is itself a logical and full geometry, then why do we have to introduce the Euclidean connection?

I believe there are two answers. The first is that Euclidean geometry is so closely interwoven with the CCS that we cannot fully explain the CCS without recourse to it: for the CCS to act as a model of the world it has to be first of all a valid model of the Euclidean system. The second, more fundamental, is that the CCS and its analytic core simply do not address the relationship between its logical structure and the world. We may understand the validity of the CCS as a geometrical system, but this doesn't bring us any closer to an understanding of its actual engagement with the world's physical reality. To gain that, we must return to the question of the definitions and postulates of Euclid.

¹ Bertrand Russell, 'Principles of Mathematics' (New York, W. W. Norton, orig. 1903), p. 10 (for discussion of pure mathematics) and p. 372 (for discussion of ideal geometry).

² A. G. Molland, 'Shifting the Foundations: Descartes's Transformation of Ancient Geometry', in *Historia Mathematica* 3 (1976), pp. 21-49 (p. 24).

³ Marvin Jay Greenberg, *Euclidean and Non-Euclidean Geometries* (New York, W. H. Freeman, 1974), p. 8.

⁴ Thomas L. Heath (trans. from text of Heiberg), *The Thirteen Books of Euclid's Elements, Vol 1* (New York, Dover Publications, 1956).

⁵ *Ibid.*, p.118.

⁶ Johann Kiesewetter, *Anfangsgründe* (1802) quoted from and translated by Jeremy Heis, 'Leibniz versus Kant on Euclid's Axiom of Parallels' [under review] (p.27).

⁷ Albert Einstein, 'Geometry and Experience' (1921), in *Beyond Geometry*, ed. by Peter Pesic (New York: Dover Publications, 2007), pp. 147-157 (p. 148).

⁸ See for instance: Robin Hartshorne, *Geometry: Euclid and Beyond* (New York, Springer, 2000), pp. 296-301., Marvin Jay Greenberg, *Euclidean and Non-Euclidean Geometries* (New York, W. H. Freeman, 1974), pp. 119-129., Roberto Bonola, *Non-Euclidean Geometry* (New York, Cosimo, 2007, orig. 1912). pp. 1-21.

⁹ Research by Janos Bolyai, Nikolai Lobachevsky, Karl Friedrich Gauss, culminating in Bernhard Riemann 'On the Hypotheses that Lie at the Foundations of Geometry' (1854), in *Beyond Geometry*, ed. by Peter Pesic (New York: Dover Publications, 2007), pp. 23-40. See also Marvin Jay Greenberg, *Euclidean and Non-Euclidean Geometries* (New York, W. H. Freeman, 1974), pp. 140-176.

¹⁰ First confirmed by Arthur Eddington in 1919, in observations of distortions of light paths of stars during an eclipse of the sun.

¹¹ I refer here to the modern CCS. The term 'Cartesian' was first used in relation to a coordinate system by Jean Bernoulli in 1692. See Carl B. Boyer *History of Analytic Geometry* (New York, Dover Publications, 2004, orig. 1956), p.133.

¹² See for instance Nick Huggett, *Space from Zeno to Einstein* (Cambridge, Massachusetts: MIT Press, 1999).

¹³ "Indeed, not only do its absurd consequences convince us how confused and incongruous with reason this doctrine is ..." Isaac Newton, 'On the Gravity and Equilibrium of Fluids' (late 1660s), in *Ibid.* pp.107-115.

¹⁴ For a general history see Carl B. Boyer *History of Analytic Geometry* (New York, Dover Publications, 2004, orig. 1956).

¹⁵ David Eugene Smith and Marcia L. Latham (trans.) *The Geometry of René Descartes* (New York, Dover Publications, 1954, orig. 1637), p. 50.

¹⁶ A. G. Molland, 'Shifting the Foundations: Descartes's Transformation of Ancient Geometry', in *Historia Mathematica* 3 (1976), 21-49 (p. 22).

¹⁷ The process of derivation is explained by Descartes in David Eugene Smith and Marcia L. Latham (trans.) *The Geometry of René Descartes* (New York, Dover Publications, 1954, orig. 1637), p. 51. A more detailed explanation is given in David Dennis, 'René Descartes' Curve-Drawing Devices: Experiments in the Relations Between Mechanical Motion and Symbolic Language', in *Mathematics Magazine* Vol 70 Issue 3 (June 1997), pp. 163-174 (p. 166).

¹⁸ See A. G. Molland, 'Shifting the Foundations: Descartes's Transformation of Ancient Geometry', in *Historia Mathematica* 3 (1976), 21-49 (pp. 34-42) and Marco Panza 'Rethinking Geometrical Exactness', preprint submitted to *Historia Mathematica* (September 2010).

¹⁹ Carl B. Boyer *History of Analytic Geometry* (New York, Dover Publications, 2004, orig. 1956), p. 156ff., and J. L. Coolidge 'The Beginnings of Analytic Geometry in Three Dimensions' in *The American Mathematical Monthly* Vol 55 No 2 (February 1948).

²⁰ Claude Rabuel '*Commentaires sur la Géométrie de M. Descartes*' (1730) (Google Books ID jf5JAAAAMAAJ) p.398ff.

²¹ David Eugene Smith and Marcia L. Latham (trans.) *The Geometry of René Descartes* (New York, Dover Publications, 1954, orig. 1637), p. 147.

²² A 'space curve' may be specified in terms of two simultaneous equations which together take in the three variables x , y and z . For instance in one equation x may be expressed in terms of y , in the second equation in terms of z . Each of these equations can be drawn as a curve on its respective plane – xy and xz . A more modern method which gives equal priority to all three planes is to specify each variable x , y and z in terms of a fourth 'parameter'.

²³ Alexis Clairaut '*Recherches sur les Courbes à Double Courbure*' (1731) (Bibliothèque Nationale de France / Gallica Bibliothèque Numérique ID bpt6k86245k) extract translated by the author.

²⁴ *Ibid.*, p.62.

²⁵ Jean-Baptiste Biot '*Essai de Géométrie Analytique*' (1802) (Google Books ID SlwOAAAQAAJ).

²⁶ Jean-Baptiste Biot's *'Essai de Géométrie Analytique'* was translated by Francis Smith for the Virginia Military Institute in 1846, with the diagrams redrawn and some reorganisation of the text. The quotations and illustrations included here are from this translation. Francis Smith, *'An Elementary treatise on Analytical Geometry'* (Google Books ID BK5XAAAAYAAJ), pp. 35 – 55.

²⁷ Thomas L. Heath (trans. from text of Heiberg), *The Thirteen Books of Euclid's Elements, Vol 2* (New York, Dover Publications, 1956), p. 194.

²⁸ Thomas L. Heath (trans. from text of Heiberg), *The Thirteen Books of Euclid's Elements, Vol 1* (New York, Dover Publications, 1956), p. 349.

²⁹ Robin Hartshorne, *Geometry: Euclid and Beyond* (New York, Springer, 2000), p. 33.

³⁰ *Ibid.*, p. 87, p. 117ff. The early relativity theorists are particularly fruitful for clear discussions of this important point: see for instance Albert Einstein, *The Meaning of Relativity* (London, Routledge, 2003, orig. 1922), p. 4; Albert Einstein, 'Space, Ether and the Field in Physics' (1930), in *Beyond Geometry*, ed. by Peter Pesic (New York: Dover Publications, 2007), pp. 173-178 (p. 174); Arthur Eddington, *Space, Time and Gravitation* (Cambridge, Cambridge University Press, 1920), p. 46 and 79. For a thorough explanation within a framework of Gauss's theories see Cornelius Lanczos, *Space through the Ages* (London, Academic Press, 1970), pp. 79-84.

³¹ Albert Einstein, 'The Problem of Space, Ether and the Field in Physics' (1934), in *Beyond Geometry*, ed. by Peter Pesic (New York: Dover Publications, 2007), pp. 187-193 (p. 188).